

## Test Report

**Client:** Jimten S.A.

**Products Tested:** Ciclon T-604 CC Macerator Unit.

**Tests undertaken:** EN12050-3:2000, Sections 4, 5, 6, 7, 8, 10 & 11;  
EN12050-4:2000, Section 8 and the Water Regulations  
'Flush Volume' test: 1-50-501 (7).

**Report Number:** B146605

**Date of Issue:** 3<sup>rd</sup> June 2015.

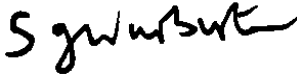
**Authorised Signatory:**   
Simon Warburton - Laboratory Director

*Client:* Jimten S.A  
*Product:* T-604 CC Macerator Unit  
*Test Criteria:* BS EN 12050-3:2000 BS EN 12050-4:2000

---

## **INDEX**

SECTION 1:	EXECUTIVE SUMMARY.....	2
SECTION 2:	SAMPLE DETAILS.....	3
SECTION 3:	TEST PROCEDURES AND RRESULTS.....	4
SECTION 4:	CONCLUSION.....	11
NOTES:	NOTES.....	12
Appendix A:	Photographs of the T-604 CC macerator that was tested	13
Appendix B:	List of materials used in the manufacture of the T-604 CC macerator.	15
Appendix C:	Photographs of the T-604 CC Labels	17
Appendix D:	Copy of the electrical and hydraulic characteristics table	19

Client: Jimten S.A  
 Product: T-604 CC Macerator Unit  
 Test Criteria: BS EN 12050-3:2000 BS EN 12050-4:2000

## 1. EXECUTIVE SUMMARY

<b>Client:</b>	JIMTEN S.A.
<b>Generic Product Type:</b>	Macerator Unit (Waste Water Lifting Plant).
<b>Model of product tested:</b>	CICLON T-604 CC
<b>Summary:</b>	<p>JIMTEN S.A. requested testing of the CICLON T-604 CC macerator to verify its compliance with the performance requirements of EN 12050-3:2000 and EN 12050-4:2000, and the Water Regulations Flush Volume requirements.</p> <p>Appendix A contains a photograph of the sample that was tested.</p> <p>This report describes the results of the tests performed on the representative samples of the CICLON T-604 CC Macerators. Samples of the Jimten CICLON T-604 CC macerators were evaluated for compliance with the requirements of: EN12050-3: 2000 Lifting plants for wastewater containing faecal matter for limited applications, Sections 4, 5, 6, 7, 8, 10 and 11 and EN12050-4: 2000 Non-return valves for faecal-free wastewater and waste water containing faecal matter', Section 8 and the UK Water Regulations Flush Volume requirements.</p> <p><b>Concluding Summary Statement:</b> The tested samples of the Jimten CICLON T-604 CC Macerator' COMPLIED with the requirements of EN12050-3:2000, sections 4, 5, 6, 7, 8, 10 and 11 and EN12050-4: 2000, section 8, and the UK Water Regulations 'Flush Volume' requirements.</p>

Client: Jimten S.A  
 Product: T-604 CC Macerator Unit  
 Test Criteria: BS EN 12050-3:2000 BS EN 12050-4:2000

## 2. SAMPLE DETAILS

<b>Models Tested:</b>	CICLON T-604 CC Macerator
<b>Submitting Organisation:</b>	Jimten S,A.
<b>Address of Submitting Organisation:</b>	Carretera de Ocaña 125 C.P. 0.31140 ALICANTE ESPAÑA
<b>Manufacturing Organisation:</b>	As above.
<b>Address of Manufacturing Organisation:</b>	As above
<b>Date of Sample Receipt:</b>	1 <sup>st</sup> May 2015.
<b>Condition of Sample on Receipt:</b>	New.
<b>NSF-WRc Sample Numbers:</b>	Samples: B146605A – B146605B
<b>Description of samples:</b>	Macerator units. (Waste Water Lifting Plants).
<b>Sampling procedure:</b>	Not applicable.
<b>Observations:</b>	See Appendix A, which contains a photograph showing the design T-604 CC macerator that was tested.
<b>Date Test Started:</b>	25 <sup>th</sup> March 2015.
<b>Date Test Completed:</b>	2 <sup>nd</sup> June 2015.

Client: Jimten S.A  
Product: T-604 CC Macerator Unit  
Test Criteria: BS EN 12050-3:2000 BS EN 12050-4:2000

---

### **3. TEST PROCEDURE AND RESULTS**

#### **EN12050-3: 2000, Sections 4, 5, 6, 7, 8, 10 & 11**

##### **SECTION 4: REQUIREMENTS**

###### **4.1 Control Equipment**

The T-604 CC macerator is designed with control equipment that allows it to operate automatically.

###### **4.2 Electrical Equipment**

The T-604 CC manufacturer provided NSF-WRc Ltd with a copy of the electrical testing report. (A copy is held in the laboratory testing file).

###### **4.3 Container**

The T-604 CC unit is of a closed design, that is watertight and odour tight.

###### **4.4 Manufacturer's Statement**

The manufacturer has supplied a table with the electrical and hydraulic characteristics for the T-604 CC macerator. Please see Appendix D which contains a copy of the characteristics table.

##### **SECTION 5: CONSTRUCTION PRINCIPLES**

###### **5.1 PUMPING OF SOLIDS**

The faecal lifting plant for limited applications shall be capable of pumping domestic wastewater including all the solid matter it usually contains, as defined in EN 12056-1. It shall be designed in such a way that solid matter does not accumulate.

The T-604 CC macerator proved compliance with this requirement, as it passed the 'Pumping of Solids' test stated in section 8.

###### **5.2 PIPE CONNECTIONS**

(i) The dimensions of inlet, discharge and ventilating connections shall permit the use of standard pipe sizes. Connections shall be flexible and shall withstand the maximum pump pressure without leaking.

The T-604 CC macerator is supplied with a 32mm solvent weld pipe adaptor to be fitted to the non-return valve on the outlet pipe. The connection was flexible and it withstood the maximum pump pressure without leakage during the testing.

(ii) The WC inlet connection shall facilitate connection of a WC according to EN 33 or EN 37.

Client: Jimten S.A  
Product: T-604 CC Macerator Unit  
Test Criteria: BS EN 12050-3:2000 BS EN 12050-4:2000

---

The T-604 CC macerator is supplied with a WC pan connector that allows connection of WC's manufactured to EN 33 and EN 37.

(iii) Wastewater flows shall be unimpeded in accordance with EN 12056-1.

The T-604 CC macerator complied with the requirement, it exceeded the minimum flow velocity requirement of 0.70 m/s.

### 5.3 **VENTILATION**

The container shall be adequately ventilated. Ventilation into a room shall be odour free.

The T-604 CC macerator is ventilated via an activated carbon cartridge that is fitted to the top of the unit.

### 5.4 **MINIMUM FLOW VELOCITY**

The flow velocity in the discharge pipework shall be at least 0.7 m/s at the duty point. The duty point shall be calculated according to EN12056-4. The minimum flow rate shall be calculated in accordance with the equation:

$$Q_{min} = v \times \frac{\pi}{4} \times 10^{-3} \times d^2$$

The minimum measured flow velocity in the discharge pipe was 1.25m/s, therefore the Ciclon T-604 CC Macerator' **COMPLIES** with the requirements of Clause 5.4 of EN 12050-3:2001.

### 5.5 **MINIMUM PASSAGE OF THE PLANT**

The free passage in faecal lifting plants for limited applications between the WC inlet to the plant and the suction connection to the pumping device shall be at least 25 mm. The passage between additional connections for faecal-free waste water and the suction connection of the pumping device shall be a minimum of 10mm.

The minimum free passage between the WC inlet of the plant and the pump suction connection was measured at 37mm. The minimum free passage between the additional connections and the pump suction connection was measured at 22mm. The Ciclon T-604 CC Macerator' therefore **COMPLIES** with the requirements of Clause 5.5 of EN 12050-3:2001.

### 5.6 **MINIMUM SIZE OF DISCHARGE PIPEWORK**

Discharge connections, discharge pipework and non-return valves for macerating faecal lifting plants for limited applications shall have a minimum bore diameter of 20 mm.

The bore of the inlet and outlet pipe work was measured at 24.9mm and therefore the 'T-604 CC' macerator **COMPLIES** with the requirements of Clause 5.6 of EN 12050-3:2001.

Client: Jimten S.A  
Product: T-604 CC Macerator Unit  
Test Criteria: BS EN 12050-3:2000 BS EN 12050-4:2000

---

## 5.7 **FIXING DEVICES**

Faecal lifting plants for limited applications shall be designed to prevent rotation or floatation.

The 'T-604 CC' macerator container is moulded with 2 fixing points that allows it to be fixed to the floor to prevent rotation or floatation. The macerator is designed to be installed with a Frame that contains a flushing cistern. The frame incorporates supports for the macerator, which will also prevent rotation. (Please refer to installation manual for further information, a copy of which is retained in the test file).

## 6 **MATERIALS**

A full and comprehensive list of materials used in the construction of the 'T-604 CC' macerator has been submitted by the applicant and is included in this report (see Appendix B). The materials used in the manufacture of this product comply with the requirements of EN 12050-3:2001.

## 7 **TESTING DOCUMENTATION AND SAMPLES TO BE TESTED**

For the initial testing the following documentation shall be provided:

- Drawings, including information on materials used.  
The manufacturer has supplied a full list of materials used. Please see Appendix B which contains a copy of the list of materials.
- Operating and maintenance instructions.  
A copy of the operating and maintenance instructions that was supplied with the T-604 CC macerator is held in the test file.

## 8 **TESTING**

### 8.1 **GENERAL**

The T-604 CC macerator unit that was tested complied with the shape, dimensions and materials given in the test documentation. On completion of testing, the T-604 CC macerator complied with the requirements of EN 12050-3: 2001. The water temperature during the testing did not exceed 35°C.

### 8.2 **TEST CONDITIONS**

The hydraulic characteristics stated by the manufacturer, was confirmed. Before commencing the testing, the pumping device was run continuously for over 1 minute. Testing of the hydraulic characteristics was carried out over a period of between 5 to 10 minutes. Based on the hydraulic characteristics determined by the testing, the T-604 CC macerator proved compliance with the minimum flow velocity of 0.7 m/s as detailed in section 5.4 of the standard. The measured flow velocity was 1.25m/s.

### 8.3 **TESTING FOR LEAKS**

During the water and odour test the plant full of water, shall withstand an overpressure of  $0.080 \pm 0.005$  bar (Water column of 816mm +/- 50mm of water), for 15 min without any visible leakage.

During the initial 15 minute overpressure test on sample A, leakage was evident from the lid seal 12 minutes into the 15 minute test. This constituted an initial failure.

*Client:* Jimten S.A  
*Product:* T-604 CC Macerator Unit  
*Test Criteria:* BS EN 12050-3:2000 BS EN 12050-4:2000

---

Sample B was then tested, and again leakage was evident from the lid seal. We contacted the customer, they requested that we check to see if the lid fixing screws could be tightened. On checking this, each of the fixing screws on both A and B samples, were able to be tightened approximately a further 1 turn. We tightened each of the fixing screws on each of the models and re-conducted the leakage test on both A and B samples. There was no visible signs of leakage from either of the samples during the 15 minute re-tests, (Note: On contacting the customer with feedback following the re-testing, they stated that they would review the production torqueing requirements and informed us that a pressure test is conducted on each model at the end of production). Both samples A and B passed the re-test, therefore the 'Ciclon T-604 CC macerators' **COMPLIES** with the requirements of Clause 8.3 of EN 12050-3:2001.

## **8.4 LIFTING EFFECTIVENESS OF THE FAECAL LIFTING PLANT FOR LIMITED APPLICATIONS**

### **8.4.1 PUMPING OF SOLIDS**

The lifting effectiveness of faecal lifting plants for limited applications shall be tested by using the arrangement shown in Figure 2 of EN12050-3. Faecal lifting plants for limited applications integrated into the WC shall be connected directly to the discharge pipe. Materials used in the test shall be:

- Sheets of double layered toilet paper;
- Sheets of moistened toilet paper of fleece quality (size 195mm x 100mm);
- Sanitary tampons.

The Ciclon T-604 CC macerator was set up in accordance with the test arrangement shown in Figure 2 of the standard and the manufacturer's installation instructions with a 32mm discharge pipe and the 6 litre cistern on a frame that is supplied with the macerator unit. A Twyford's floor standing back to wall pan was directly connected to the T-604 CC unit.

### **8.4.2 TEST PROCEDURE**

A faecal lifting plant for limited applications, together with its non-return valve shall be connected to a WC. The suction and pumping effectiveness shall be tested by flushing the WC 10 times and adding a number of test materials as outlined in EN 12050-3: 2000, section 8.4.2. During the test the water level in the container shall not rise more than 180mm above the base level.

The Ciclon T-604 CC was set up as detailed above and the suction and pumping effectiveness was tested by flushing the WC 10 times and adding the test material as follows:

Flush 1: 12 sheets of double layer toilet paper

Flush 2: 12 sheets of double layer toilet paper

Flush 3: 4 sheets of moistened toilet paper of fleece quality

Flush 4: 1 sanitary tampon of normal size

Flush 5: 12 sheets of double layer toilet paper

Flush 6: 12 sheets of double layer toilet paper

Flush 7: 4 sheets of moistened toilet paper of fleece quality

Flushes 8 to 10: water flushes without addition of test material.

*Client:* Jimten S.A  
*Product:* T-604 CC Macerator Unit  
*Test Criteria:* BS EN 12050-3:2000 BS EN 12050-4:2000

---

During the test the water level in the container rose by 175 mm and therefore the 'Ciclon XS T-604 CC macerator' **COMPLIES** with the requirements of Clause 8.4.2 of EN 12050-3:2001.

#### **8.4.3 COMPLETION OF TEST**

After testing as described above, there shall be no test material deposited except in negligible amounts. The maximum negligible amount shall be less than 20% of the total dry weight of the material added. (This is regarded as a negligible amount).

The total dry weight of material deposited at the end of the test was less than 10.0% of the total dry weight of the materials that were initially added. The standard states that amounts less than 20% of the total dry weight of materials that are initially added are regarded as negligible, therefore, the 'Ciclon T-604 CC macerator' **COMPLIES** with the requirements of Clause 8.4.3 of EN 12050-3:2001.

#### **8.4.4 MAXIMUM INFLOW**

In addition to the test described in 8.4.2, plants with additional connections shall undergo a maximum inflow test. The Ciclon T-604 CC has an additional connection, thus the 'maximum inflow' test was conducted as detailed below.

A constant inflow of  $(0.50 \pm 0.02)$  l/s shall be discharged into the lifting plant. During this constant inflow, the WC shall be flushed twice at approximately 2 min intervals. Each WC flush shall take place at the exact moment that the lifting plant switches on. During this test the water level in the container shall not rise more than 180mm above the base level.

During the test the water level rose to a maximum height of 130 mm and therefore the 'Ciclon T-604 CC macerator' **COMPLIES** with the requirements of Clause 8.4.4 of EN 12050-3:2001.

#### **8.4.5 ADDITIONAL CONNECTIONS**

If the invert of an additional connection is less than 180mm above the base level of the plant, then the installation of the additional sanitary appliance shall be carried out in accordance with the manufacturer's instructions.

The invert of the additional connection on the Ciclon T-604 CC is less than 180mm above the base of the unit, thus, the 'Additional connections' test was conducted as detailed below:

This test shall be carried out to ensure that during WC flushing the water in the trap of the sanitary appliance does not become contaminated nor rise by more than 25 mm.

During the test there was no rise in the water level within the trap, and the measured opacity of the water in the trap that was connected to the additional connection was 0.000% prior to the test and 0.001% following the test. The water in the trap of the sanitary appliance that was connected to the additional connection did not become contaminated. The 'Ciclon T-604 CC macerator' **COMPLIES** with the requirements of Clause 8.4.5 of EN 12050-3:2001.

Client: Jimten S.A  
Product: T-604 CC Macerator Unit  
Test Criteria: BS EN 12050-3:2000 BS EN 12050-4:2000

---

## 10 **MARKING**

Faecal lifting plants for limited applications complying with this standard shall be identified in a permanent and legible manner with the manufacturer's symbol and EN12050-3. A warning indication shall be present, containing a prohibition on flushing hygiene articles, fibrous matter, etc. through the WCs.

The T-604 CC macerator has a label attached to the side of the unit. The label was printed with the manufacturer's name, model number, EN 12050-3, maximum discharge height and electrical data. Therefore the 'Ciclon T-604 CC macerator' **COMPLIES** with the requirements of Clause 10 of EN 12050-3:2001. A warning label is also supplied with the unit. This label details what materials are prohibited to be flushed through the unit. Appendix C contains a photograph of the labels.

## 11 **INSTALLATION, OPERATION AND MAINTENANCE**

The 'Ciclon T-604 CC' macerator is supplied with installation and maintenance instructions which contains details on correct positioning, outlet pipe size, maximum height and orientation. It also includes electrical and detailed assembly information along with a schematic diagram of each component of the macerator and a full technical specification.

The 'Ciclon T-604 CC macerator' therefore **COMPLIES** with Clause 11 of EN 12050-3:2001.

The 'Ciclon T-604 CC' is supplied with a non-return valve for connection onto the outlet of the unit. The non-return valve was tested to the requirements of Section 8 of EN12050-4: 2001.

### 8.1 **GENERAL REQUIREMENTS**

Testing was carried out on the non-return valve that was supplied with the T-604 CC macerator. The testing demonstrated compliance with the construction principles given in clause 5 of EN 12050-4: 2001

### 8.2 **FUNCTIONAL TESTING**

#### 8.2.1 **GENERAL REQUIREMENTS**

The application of the valve is for wastewater containing faecal matter.

#### 8.2.3 **WASTEWATER CONTAINING FAECAL MATTER**

The operation of the non-return valve was tested as part of the faecal lifting plant testing as stated in section 8.4.2 of EN 12050-3:2001. The pieces of test material passed through the non-return valve. After the test, the non-return valve was opened and checked. No material had settled within the valve.

*Client:* Jimten S.A  
*Product:* T-604 CC Macerator Unit  
*Test Criteria:* BS EN 12050-3:2000 BS EN 12050-4:2000

---

#### 8.2.4 **LEAKAGE**

The non-return valve shall be subjected to a backpressure of 0.2 bar for 10 min using clean water. During this period no more than 0.5 litres of water shall pass through a size 32mm valve.

During and after the test was completed, no leakage through the non-return valve was observed, therefore the non-return valve supplied with the 'Ciclon T-604 CC macerator' **COMPLIES** with the requirements of Clause 8.2.4 of EN 12050-4:2001.

#### 8.2.5 **PRESSURE TESTING**

Due to the fact that the non-return valve is supplied as part of the T-604 CC macerator, the non-return valve was pressure tested to 1.5 times the maximum pump pressure of the plant, which is 6 metre head. The non-return valve was pressure tested at a test pressure of 0.9 bar for a duration of 10mins in both the open and closed positions. There was no visible leakage from the valve over the test durations.

### **UK WATER REGULATIONS REQUIREMENTS**

- **PROCEDURE TO DETERMINE THE FLUSH VOLUME: IGN 1-50-501 (7)**

To comply with UK Water Regulations and therefore to be installed and used in the UK, the flush volume of the WC must be a maximum 6 litres.

A 6 litre close coupled WC suite was installed onto the T-604 CC macerator and the flush volume test was conducted in accordance with the procedure to determine the flush volume. The WC was flushed a total of 5 times and the mean flush volume was recorded at 5.80 litres. The mean flush volume was less than 6 litres, therefore the 'Ciclon T-604 CC macerator' **COMPLIES** with the requirements of the UK Water Regulations.

*Client:* Jimten S.A  
*Product:* T-604 CC Macerator Unit  
*Test Criteria:* BS EN 12050-3:2000 BS EN 12050-4:2000

---

## **4. CONCLUSION**

The supplied test samples of the Jimten 'Ciclon T-604 CC macerator' **COMPLIED** with the requirements of the tested portions of EN 12050-3: 2001 'Lifting plants for wastewater containing faecal matter for limited applications', Sections 4, 5, 6, 7, 8, 10 & 11 and the non-return valve supplied with the T-604 CC macerator complied with EN12050-4: 2001 'Non-return valves for faecal-free wastewater and waste water containing faecal matter': section 8; and also the UK Water Regulations Flush volume requirements.

*Client:* Jimten S.A  
*Product:* T-604 CC Macerator Unit  
*Test Criteria:* BS EN 12050-3:2000 BS EN 12050-4:2000

---

## NOTES

1. This report is issued in accordance with the laboratory accreditation requirements of the United Kingdom Accreditation Service (UKAS). NSF-WRc is UKAS accredited against ISO/IEC 17025:2005 for calibration and testing, laboratory numbers 0248 and 0626 respectively. For details of the laboratory Schedule of Accreditation please see the UKAS website ([www.ukas.org](http://www.ukas.org)).
2. The laboratory provides traceability of measurement to recognised national standards, and to units of measurement realised at the National Physical Laboratory or other recognised national standards laboratories.
3. Opinions and interpretations in this report are outside the scope of UKAS Accreditation.
4. The results specified in this report relate only to the sample(s) of the product submitted for testing. Any change in the source or nature of the product or materials used in the product, method of manufacture or application could affect the performance of the product.
5. This test report does not constitute approval or endorsement of the product by either NSF-WRc or its parent companies.
6. The contents of this report are the copyright of NSF-WRc Ltd and all rights are reserved. No part of this publication may be reproduced, stored in a retrieval system in any form or by any means electronic, mechanical, photocopying, recording or otherwise, without prior written consent of NSF-WRc Ltd.
7. Any queries regarding this report should be addressed to the authorised signatory or to the Technical Manager at NSF-WRc. Copies of reports are retained by NSF-WRc for seven years after issue.
8. Non UKAS accredited tests or tests which have been subcontracted will be identified in the following manner: -
  - Tests marked \$: are not included in the NSF-WRc UKAS accreditation schedule
  - Tests marked @ have not been performed by NSF-WRc and the approved subcontractor is not UKAS accredited for the test(s)
  - Tests marked \* have not been performed by NSF-WRc and the approved subcontractor is UKAS accredited for the test(s)

*Client:* Jimten S.A  
*Product:* T-604 CC Macerator Unit  
*Test Criteria:* BS EN 12050-3:2000 BS EN 12050-4:2000

---

## **APPENDIX A**

Photograph of the T-604 CC macerator that was tested.

Client: Jimten S.A  
Product: T-604 CC Macerator Unit  
Test Criteria: BS EN 12050-3:2000 BS EN 12050-4:2000

---



Photograph of T-604 CC model

*Client:* Jimten S.A  
*Product:* T-604 CC Macerator Unit  
*Test Criteria:* BS EN 12050-3:2000 BS EN 12050-4:2000

---

## **APPENDIX B**

List of materials used in the manufacture of the T-604 CC macerator.

Client: Jimten S.A  
 Product: T-604 CC Macerator Unit  
 Test Criteria: BS EN 12050-3:2000 BS EN 12050-4:2000



## 10. SPARE PARTS.

### SANITARY MACERATOR BREAKDOWN AND CASSET SET.

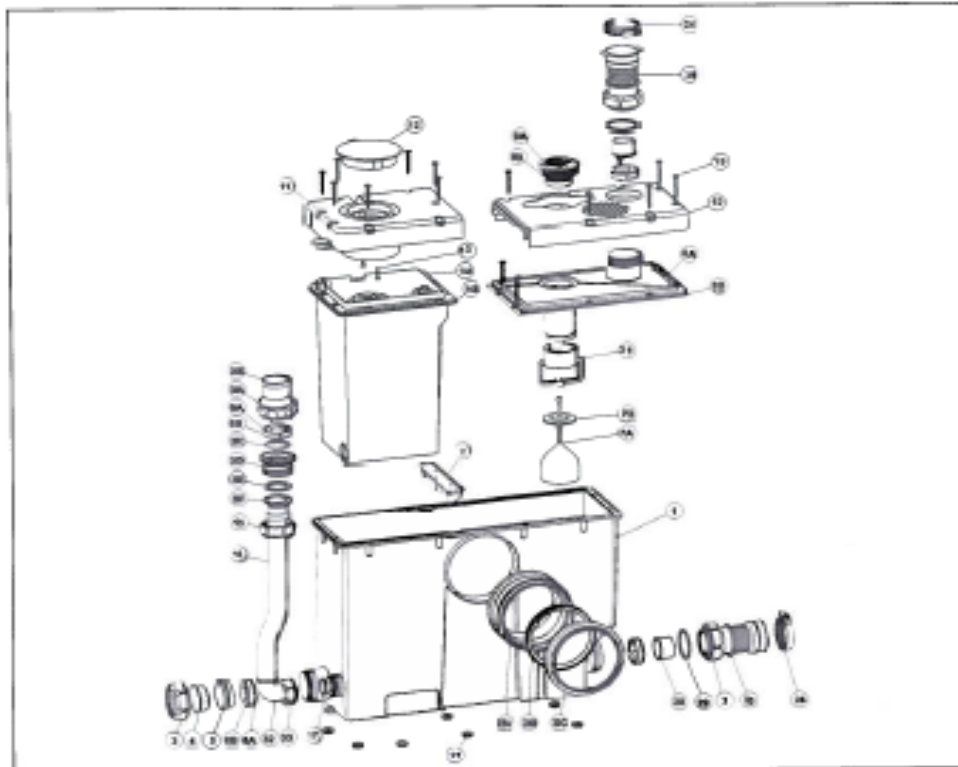

- |   |   |
|---|---|
| 1. MACERATOR BODY                               | 16. PVC PIPE  |
| 2. CROSSBAR (ABS)                               | 17. O-RING OUTLET ELBOW (NBR)                       |
| 3. 1" NUT (PP)                                  | 18. FIXING SCREW (AC. INOX. AISI-304)               |
| 4. 1" CHOKE PLUG (PVC)                          | 19A. NUT CLIP FOR NON-RETURN VALVE (PP)             |
| 5. 1" BLUE JOINT (EW)                           | 19B. NON-RETURN VALVE LOWER PART                    |
| 6A. NON-RETURN VALVE JOINT                      | 20C. 31X2 O-RING (NBR)                              |
| 6B. NON-RETURN VALVE HOLDER                     | 20D. NON-RETURN VALVE LOWER PART (PP)               |
| 7A. VENTILATION BUDY (PP)                       | 20E. BUTT JOINT (NITRIL)                            |
| 7B. VENTILATION BUDY JOINT                      | 20F. SOLVENT COUPLING (PVC)                         |
| 8A. CLOSING LID TANK                            | 21. LOWER TOPS                                      |
| 8B. WATERTIGHTNESS JOINT                        | 22A. WC CONNECTION COUPLING (EW)                    |
| 9A. ACTIVE CARBON TANK (PP)                     | 22B. WC CONNECTION JOINT.                           |
| 9B. ACTIVE CARBON LID (PP)                      | 22C. WC CONNECTION RING (PP)                        |
| 10. TANK FACING LID (PP)                        | 24. METAL CLAMP 32-50 (AC. INOX. W2)                |
| 11. CASSET FACING LID. (PP)                     | 25. FLEXIBLE CONNECTION RE-INFORCEMENT CLINDER (PP) |
| 12. ROUND FACING LID. (PP)                      | 26. WASHER FOR FLEXIBLE CONNECTOR. (PP)             |
| 13. ROUND FACING LID 42X50 (AC. INOX. AISI-304) | 30. FLEXIBLE CONNECTION                             |
| 14A. CASSET (PP COPC)                           | 31. BUDY GUIDE. (PP)                                |
| 14B. CASSET WATERTIGHTNESS JOINT                | 32. OUTLET ELBOW (PVC)                              |
| 15. 1" NUT (PP)                                 | 33. 1" NUT (PP)                                     |

32 - INSTRUCTIONS AND MAINTENANCE GUIDE

List of materials used in the assembly of the T-604 CC unit

*Client:* Jimten S.A  
*Product:* T-604 CC Macerator Unit  
*Test Criteria:* BS EN 12050-3:2000 BS EN 12050-4:2000

---

## **APPENDIX C**

Photographs of the T-604 CC labels.

Client: Jimten S.A  
Product: T-604 CC Macerator Unit  
Test Criteria: BS EN 12050-3:2000 BS EN 12050-4:2000

---



T604-CC labels

*Client:* Jimten S.A  
*Product:* T-604 CC Macerator Unit  
*Test Criteria:* BS EN 12050-3:2000 BS EN 12050-4:2000

---

## **APPENDIX D**

Copy of the electrical and hydraulic characteristics table  
for the T-604 CC

Client: Jimten S.A  
Product: T-604 CC Macerator Unit  
Test Criteria: BS EN 12050-3:2000 BS EN 12050-4:2000

---

02/06/2015

**Hydraulic and electrical characteristics Macerator CICLON T-604 CC and CICLON T-604 CS**

<b>P(Bar)</b>	<b>Q(l/s)</b>	<b>VEL (m/s)</b>	<b>VOLTIOS(V)</b>	<b>INTENSITY(A)</b>	<b>POWER(W)</b>
0.35	1,37	2,5	217,9	1,56	339,9
0.4	1,34	2,5	217,9	1,54	335,5
0.4	1,22	2,2	218,5	1,51	329,9
0.5	1,13	2,1	219,0	1,48	324,1
0.55	1,05	1,9	217,9	1,44	313,7
0.6	0,94	1,7	217,9	1,39	302,8
0.7	0,83	1,5	217,9	1,34	291,9



Tue 02/06/2015 15:17

Antonio RODRIGUEZ <antonio.rodriquez@jimten.com>

RE: Electrical and Hydraulic characteristics tables

Copy of the electrical and hydraulic characteristics table  
for the T-604 CC