



Ficha Técnica

A-305 Codo H/H de 45° con 2 tomas laterales de Ø50

Evacuación - Accesorios con tomas



Referencia	Medidas	Características	u./caja
33043058	110-50-50	-	20

Cotas

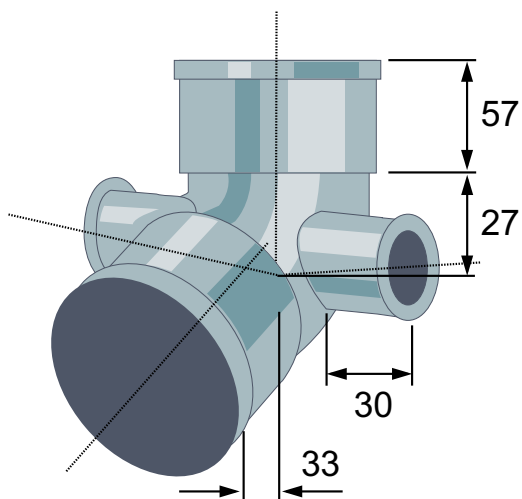

Documentación



Certificados



Tarifas

