

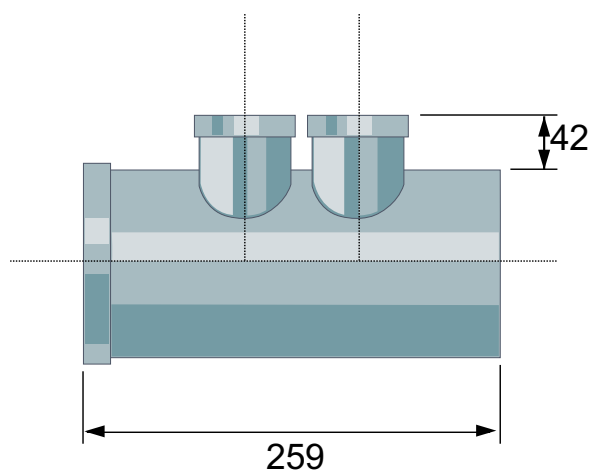

Referencia	Medidas	Características	u./caja
33040591	110-50-50	-	10

Cotas



Documentación



Certificados



Tarifas

