

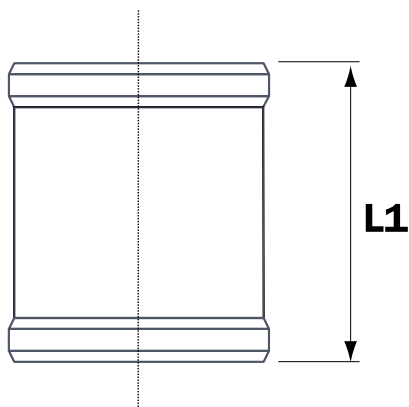

Referencia	Medidas	Características	u./caja
33040093	32	N AENOR B-s1,d0	150
33040094	40	N AENOR B-s1,d0	125
33040095	50	N AENOR B-s1,d0	100
33040096	75	N AENOR B-s1,d0	20
33040097	90	N AENOR B-s1,d0	20
33040098	110	N AENOR B-s1,d0	24
33040099	125	N AENOR B-s1,d0	30

### Cotas



Referencia	DN	L1
33040093	32	50
33040094	40	59
33040095	50	70
33040096	75	94
33040097	90	107
33040098	110	125
33040099	125	139

## Documentación



## Certificados



## Tarifas

